

**Architectural Guidelines for
Shadow Mountain Ranch
Community Association (SMRCA)**

2019

Table of Contents

Introduction	3
Directives	3
Process for Approval	3
Disclaimer of Responsibility	4
Remedies.....	4
Variances.....	5
Appeal Process	5
Architectural and Material Standards.....	5
I. Landscape – General.....	5
II. Lighting.....	6
III. Decorative Landscape Elements	7
IV. Patio Slabs, Patio Covers, and Gazebos	7
V. Pools, Spas, and Related Improvements	8
VI. Perimeter and Adjoining Walls, Fences, Gates, and Hardscape	8
VII. Awnings and Shutters	11
VIII. Windows and Glass Door Treatments	11
IX. Other Structures and additional modifications.....	112
X. Signage.....	116
XI. Security	117
XII. Vehicle Covers	118
Appendix:	20
Architectural Submittal Checklist Exhibit A	20
Architectural Review Application Form Exhibit B	21
Impacted Neighbor Statement Exhibit C	222
Patio Cover Checklist Exhibit D	233
Driveway Extensions Illustrations Exhibit E.....	24

Introduction

These guidelines are intended as a supplement to the Covenants, Conditions, and Restrictions (“CC&Rs”) of the Shadow Mountain Ranch Community Association (“SMRCA”). However, if there is any conflict between the CC&Rs and these Architectural Review Guidelines (“ARC Guidelines”), the CC&Rs will determine the resolution to the conflict. IT IS YOUR RESPONSIBILITY TO READ THE CC&Rs THOROUGHLY.

Directives

1. The Architectural Review Committee (ARC) does not seek to restrict individual creativity or personal preferences, but rather to assure the continuity in design to preserve and improve the appearance of the Community and the property values within.
2. The ARC reviews all plans for the exterior improvements and additions to the residential lots and dwellings in the SMRCA. These improvements include, without limitation, additions, modifications, and alterations to the residential dwellings such as pools, spas, patios, room additions, gazebos, and installation of hardscape and landscape.
3. The ARC is composed of no less than three and no more than five members. Additionally, a licensed professional architect may serve or provide consultation to the ARC at the expense of the Owner(s) if requested in writing by the ARC.
4. Approval of the plans by the ARC or by the Board of Directors (Board”) in no way constitutes verification or certification of the structural integrity of any design. It is the sole responsibility of the Owner(s) to ensure the structural integrity and soundness of any improvement. It is also the Owner’s responsibility to ensure compliance with all government regulations and building codes, as well as the CC&Rs, and to obtain all necessary permits.
5. No Owner shall store or permit to accumulate any construction materials such as dirt, rock, pallets, sod, plants, trees, or construction equipment on the streets or in Common Elements within the community for the period longer than seventy-two (72) hours.

Process for Approval:

1. Prior to the commencement of any work on any improvement on any lot, an “Architectural Review Application Form” must be submitted by the Owner to the ARC. No work is to begin prior to the receipt of the approval of the ARC.
2. All submittals must be in accordance with the ARC Guidelines and the CC&Rs and must include the ARC application documents:
 - a. A legible, completed and signed “Architectural Review Application Form” (available on the SMRCA website.)

- b. An “Impacted Neighbor Statement” completed and signed (available on the SMRCA website.)
 - c. The plans, sketches, pictures, and drawings setting forth the details of the proposed improvement including a materials and plant list (Contractor proposal sketches are a good source for the plans to be submitted.) The ARC may request any additional statements, drawings, plans, materials list, or other information from the Owner(s) that it deems necessary for its review of the proposed improvement.
 - d. If an improvement has been approved by the ARC and the project requires any alterations or modifications, an amended “Architectural Review Application Form” must be submitted to the ARC and approved before such alterations or modifications may be commenced. The ARC will attempt to make these mid-project applications a priority.
 - e. Checklists: See Appendix Exhibit A.
3. Approval or Disapproval of Completed Application. In the event the ARC or the Board fails to approve or disapprove an Architectural Review Application within sixty (60) days after the plans and specifications have been submitted to it, the plans and specifications shall be deemed to be disapproved. See Article XII, Section 12.4 of the CC&Rs.

Disclaimer of Responsibility:

Provided that the ARC members act in good faith, neither the ARC nor any member thereof shall be held liable to any Owner or any other person for any damage, loss, or prejudice suffered or claimed on account of the review of any plans, specifications, or materials. The review, and any subsequent approval or disapproval, is not to be considered an opinion as to whether or not the plans, specifications or materials are defective, or whether the construction methods or performance of the work proposed therein is defective, or whether the facts therein are correct or meet the applicable building codes. Owners are fully responsible for obtaining any necessary permits from any government agencies as applicable.

Remedies:

Failure to submit a completed Architectural Review Application Form to the ARC or failure to complete improvements consistent with the approved plans is a violation of the CC&Rs. If an Owner fails to remedy any non-conforming improvement, the Board shall request the Owner’s presence at a scheduled hearing. If the issue is not resolved or the Owner does not appear at the scheduled hearing, the Board may institute reasonable and appropriate actions, including monetary fines to ensure that the non-conforming improvements are modified or removed.

Any architectural element may be reviewed, as installed, by the Board. If any such installation is found to be not in compliance with the CC&Rs or these ARC Guidelines, the Board may require that installation to be modified or removed at the Owner’s expense.

Variations:

Subject to the CC&Rs, the ARC may recommend, but only the Board may approve a variance to any provision contained in the CC&Rs or these ARC Guidelines when circumstances such as the topography, natural obstructions, health, or environmental consideration may require such variations.

The ARC will use the ARC Guidelines for the purpose of reviewing proposed improvements, but may individually consider the merits of any improvement due to special conditions that are felt to provide benefits to the adjacent area, the specified site, or to the community as a whole.

Appeal Process:

If plans are disapproved by the ARC, an Owner may appeal the adverse decision to the Board. This appeal must be in writing and received by the Board no later than thirty (30) days following the date of the letter indicating the denial of the plans as submitted. The Board will have forty-five (45) days to consider the appeal. If no decision is communicated to the Owner within the forty-five (45) day period, on the forty-sixth (46) day the Owner may consider the appeal denied.

Architectural and Material Standards

I. Landscape – General

- A. APPLICATION TO ARC - No grading, excavation, planting, or removal of any tree or existing landscape shall be commenced until the plans showing the nature, kind, shape, height, and location of the same shall have been approved by the ARC. Forms are available on www.shadowmountainranchhoa.com.
- B. LANDSCAPE- All plantings and irrigation system installations shall remain aesthetically consistent with the design and plan of the community and climatically and culturally appropriate to Southern Nevada.
- C. SMRCA COMMON ELEMENTS- No Owner shall modify landscape or otherwise improve any property that is included in the SMRCA Common Elements.
- D. HARDSCAPE COLOR SCHEMES/MATERIALS- Natural earth tones are permitted. Decorative rock, gravel, or boulders in white, green, blue, or other non-earth tone colors are not permitted if visible to neighbors or from the street. Lava rock is not permitted if visible to neighbors or from the street.
- E. REAR YARD- If no landscaping exists at time of closing, new Owner shall install rear yard landscaping within six (6) months from the close of escrow. Plans must be approved by the ARC prior to installation.
- F. PLANTINGS- Drought resistant, low water usage plant material, appropriate to the desert climate is encouraged.

1. Location of trees shall be limited to areas that will not interfere with or create a nuisance to neighboring properties upon maturity. Please Note: Some trees may have invasive root systems, which may cause problems when mature.
2. All grass must be a fescue blend, hybridized Bermuda blend, or annual rye grass developed for use in the desert. Bermuda grass is not permitted.

G. MAINTENANCE- Owners are required to maintain their property in good condition at all times. This includes regular lawn mowing, pruning of trees and shrubs, fertilizing, watering, removal of dead or diseased plants, replacement of plants, and over seeding of lawn areas and removal of debris.

H. DRAINAGE- Landscaping should be planned and completed in a manner that ensures proper drainage in accordance with the site plans. Proper drainage is required to protect the applicable Unit, the Common Elements, and the surrounding properties from the accumulation of surface waters. Drainage patterns that were established at the time of the original construction of the residence should not be disturbed unless improved drainage is the intent.

1. Drainage damages- Any landscape improvement that damages a drain pattern shall be corrected at the Owner's sole cost and expense. In addition, any damage to the Common Elements or the neighboring properties that occurs as a result of improper drainage shall be the responsibility of the party responsible for altering, interfering with, or damaging the drainage pattern.

II. Lighting

A. GENERAL PROVISIONS

1. All exterior lighting must be placed in a manner where it will not create an annoyance to neighbors or to the community. Lighting must be directed to avoid spillage of light onto adjoining property, streets and sidewalks, and Common Elements.
2. For purposes of these ARC Guidelines, lighting installed on the exterior of the house that is not designed specifically to ward off intruders is considered "decorative." For example, lighting fixtures placed to frame a garage door or to illuminate access door, other than the main entrance, fall under this guideline.
3. Lights mounted higher than six (6') feet above the ground must be pointed downward and away from neighboring residences.
4. Any lighting may be reviewed as installed by the Board. If any lighting installation is found to be out of compliance with the CC&Rs or these ARC Guidelines, the Board may require such lighting to be modified or removed.

B. LANDSCAPE

1. Indirect low level lighting is encouraged.
2. The wattage of the light bulbs used in decorative lighting shall not exceed 60 watts.

C. SECURITY LIGHTING

Please refer to, Security Lighting in *Section XI Security*.

III. Decorative Landscape Elements

- A. ELEMENTS-Statues, outdoor art, fountains, birdbaths, ponds, banners, flags, play equipment, sports courts, and all other similar landscape elements, if visible from any street or from any other property, must be approved in writing by the ARC, unless as otherwise explicitly stated in these guidelines. An exception is granted for decorative pots with live plants. Provided that no more than ten (10) decorative pots are placed on the lot, they do not require prior approval from the ARC. More than ten (10) decorative pots require prior approval from the ARC. The plastic or similar-material pot in which a plant may be purchased from the nursery/store does not constitute a "Decorative Pot" and is not permitted.
- B. FLAGS- Any flagpoles must be mounted at an angle to an exterior wall of a residence and may not exceed six (6') feet in length. Free standing flagpoles or any flagpoles not attached to a residence are not permitted. Flags must be taken down at night unless lighted.

IV. Patio Slabs, Patio Covers and Gazebos

- A. CONCRETE-DUE TO PARTICULAR CONCERN ABOUT DRAINAGE, ARC APPROVAL IS REQUIRED PRIOR TO THE POURING OF ANY CONCRETE.
- B. SETBACKS- Must be clearly indicated on any plans submitted to the ARC for approval and must meet all County code regulations.
- C. PATIO COVERS- A complete Patio Cover Checklist (Exhibit D) must be included with any patio cover or gazebo plans submitted for approval by the ARC.
1. Patio cover and gazebos may be of "Alumawood" or stucco construction which may include other materials compliant with governing building codes. All exposed wood surfaces must be finished as per paragraph "E" below.
 2. Support posts must be a minimum of six (6") inches by six (6") inches. Metal pipe supports are not permitted.
 3. The following materials are not permitted in the construction of patio covers or gazebos:
 - a. Sheet metal or sheet aluminum (except "Alumawood")

- b. Corrugated plastic, fiberglass, or metal
- c. Plastic webbing, reed, or straw-like materials
- d. Composition shingles
- e. Exposed rolled roofing

D. ROOFING DETAILS- Acceptable details are:

- 1. Open lattice ("Alumawood" or finished wood)
- 2. Solid ("Alumawood" or finished wood)
- 3. Roof tiles to match dwelling

E. SURFACES- Exposed surfacing must match or harmonize with the existing colors and materials of the dwelling.

F. GUTTERS AND DOWNSPOUTS- If used, shall be painted to match adjacent wall or trim color of the dwelling.

V. Pools, Spas, and Related Improvements

A. POOL OR SPA- Submittal of complete construction plans showing the proposed placement of the pool or spa and all related equipment is required.

B. SETBACKS- Must be clearly indicated on the site plan and meet all governing building code requirements.

C. POOL EQUIPMENT- Placement must take into consideration the proximity of neighbors and the potential for creating a possible noise disturbance to adjoining property.

VI. Perimeter and Adjoining Walls, Fences, Gates, and Hardscape

A. PERIMETER WALLS (Article IX, Section 9.8 of CC&Rs)

- 1. Perimeter walls, defined by the referenced Section of the CC&Rs, are not owned by the SMRCA and are the responsibility of the perimeter lot Owners to maintain.
- 2. Party Walls are walls that form the boundary between two lots. Party walls are not owned by the SMRCA and are the responsibility of the adjacent Owners to maintain, repair and replace. If a dispute arises between two (2) Owners alleging damage to a party wall, then the SMRCA recommends that the two (2) Owners work together to resolve the problem.
- 3. No changes or alterations shall be made to the perimeter walls or party walls.

4. No removal, partial or otherwise of perimeter walls or party walls for any purpose is permitted.
5. If the landscaping is to be modified, or plant life is to be installed within two (2) feet of a perimeter wall or party wall, or if any modifications to the lot result in a change to the existing grade, it is required and imperative that the portion of the wall below grade be waterproofed. Owners are fully responsible for correcting any damage to either side of the wall, to include leaching, efflorescence, or mold, which may be caused by water intrusion.
6. An eight (8') foot easement exists which grants the SMRCA permission to enter the rear yard of the perimeter lots to repair or replace a two (2") inch Common Element sprinkler line, located five (5') feet inside the property line of the perimeter lots. Perimeter lot Owners will be held responsible for any cost necessary to repair damage to this sprinkler line due to pool excavation, planting, or any other construction. (Please refer to your deed to see if this is applicable to your lot).

B. ADJOINING WALLS / FENCES

1. No wall or fence shall be erected or altered without prior written approval of the ARC.
2. All walls or fences shall match adjacent walls and residences and must be maintained, repaired, restored, and replaced as necessary, at the Owner's expense.
3. Any walls removed or damaged must be restored to their original condition and specifications.

C. GATES – Mesh gate liners attached to the rear surface of the gate for the purpose of blocking animal egress do not require prior approval from the ARC. No gate shall be replaced other than to original specifications without prior approval of the ARC. No wooden gates are permitted. Ornamental wrought iron gates are subject to additional guidelines (please see Section IX, A.)

1. If Mesh or decorative perforated aluminum sheeting is to be applied to the gate, the entire gate or the bottom half of the gate must be screened. Owners may not screen only the top portion of the gate.
2. Screening materials that are NOT permitted include: baby gates, cardboard, plywood and/or untreated, unpainted wood, chicken wire and chain link fencing.
3. Boulders, bricks or other such items may not be placed at the bottom of the gate so as to block animal egress.

4. Anything attached to the gate must match the color scheme of the residence and be attached in a secure and aesthetically pleasing fashion.
5. Any deviations from the stated standards require prior approval of the ARC.

D. HARDSCAPES

1. Textured surfaces such as brick, stone, and stamped or exposed aggregate concrete are encouraged. Standard grade concrete is acceptable. Plans detailing the hardscape design and color choice, represented by color chip, must have prior approval of the ARC. Painted or stained hardscape surfaces must be maintained in aesthetically attractive condition; chipped, peeling, or faded surfacing must be refinished. Hardscapes must be neutral earth tones that do not contrast with the dwelling.
2. Walkways are required to be constructed using an above-referenced material type.
3. Walkways that are parallel to the driveway must be detached from the driveway by no less than two (2) feet.
4. Walkways constructed on the side of the residence, must extend from a side gate to the end of the front landscaping where it meets the sidewalk or connects to the driveway, if applicable, pursuant to the lot's layout.

E. DRIVEWAY MODIFICATIONS – Driveways may be modified/extended consistent with the provisions listed below:

1. Owner must obtain signed ARC approval prior to the start of any driveway modification.
2. Driveway may be widened toward the main entrance (front door) of the residence only.
3. Driveway widening may not exceed 2 feet (24 inches).
4. Driveway modifications must match existing driveway finished surface (Example: If existing driveway is brushed finished concrete, the extension must also be brushed finished concrete, and not brick, pavers, stamped/or colored concrete or any other dissimilar material or finish).
5. For Driveways at Roll Curb with or without Sidewalk - New driveway construction must match top back of curb elevation or back of sidewalk elevation, whichever is applicable.

6. For Driveways at "L" Type Curb and Gutter with Driveway Curb Cut - Owner shall be required to modify driveway apron to match proposed widening. In addition to written ARC approval, the Owner shall be responsible for submitting plans to Clark County for approval and shall be responsible for all applicable Permits and Requirements prior to the start of any construction. See the Clark County website for all requirements and the Regional Transportation Commission of Southern Nevada, Planning and Engineering, Uniform Standard Drawings for current driveway design and specifications.

7. See Appendix Exhibit E Uniform Standard Drawings Clark County Area: "L" Type Curb and Gutter (drawing 216); 30" Roll Curb Residential Area (drawing 217a) and Residential Driveway (drawing 223).

VII. Awnings and Shutters

- A. WINDOW AWNINGS- Must be of a durable canvas or other approved fabric and be of solid color which complements the existing dwelling. Awnings must be replaced if they become frayed, split, torn, or faded.
- B. SHUTTERS- Decorative exterior window shutters painted to complement the existing dwelling are permitted. Shutters meeting the requirements of NRS 116.2111 are permitted.

VIII. Window and Glass Door Treatments

- A. WINDOW TREATMENTS –Must be aesthetically pleasing and make use of products or materials designed for such purpose.
1. Aluminum foil and reflective or mirrored materials of any nature, (paint, decal, tint, etc.) are not permitted.
 2. Cardboard, newspaper, and paper of any kind are not permitted.
 3. Sheets or curtains with cartoon characters, sports teams, logos, writing/verbiage or any other unsightly markings of any kind are not permitted to be visible from the exterior of the residence. If such materials have a solid neutral colored backing applied, causing the non-permitted content not to be visible from the exterior of the residence, then this window covering type may be used.
 4. Application of tint is permitted provided that it does not cause the window or glass door to have a mirrored appearance
 5. Window and glass door coverings visible from the exterior of the residence shall be complimentary to the residence and aesthetically pleasing and must be maintained in good condition.

IX. Other Structures and additional modifications

- A. Doors- Installation of screen doors does not require prior ARC approval. This exception does not apply to security bar doors, Rolladen shutters or storm doors. Ornamental entrance and side gates are allowed provided that they meet the following criteria:
1. Ornamental entrance and side gates are to be made of quality decorative wrought iron.
 2. Gates must be installed by a professional contractor and designed in a style that is complimentary to the aesthetic of the individual residence and the community.
 3. Gates should be a natural patina color that is consistent with the residence's color scheme. If painted, the finish must be maintained.
 4. The doorbell must remain accessible.
 5. No screening material that might block view to front door is to be attached to entrance gates.
 6. No ironwork or security bars of any type shall be permitted on any window.
 7. Decorative elements must be incorporated into the design of the security bars or gate. An overall design with only straight up and down bars shall not be considered a decorative design and are not allowed on any location of the residence.
 8. Gate frames or casing shape must be consistent with the architectural style of the residence i.e. arched/squared.
 9. All ornamental gate design and color choices must be submitted to the SMRCA ARC for approval.
- B. ROLLING SHUTTERS - In accordance with NRS 116.2111(3), the requests for the installation of roll-up shutters must be submitted to the ARC. Rolling shutters that face a street or a Common Elements must be designed to the maximum extent practicable to be compatible with the style of the community. They must be of a contrasting color consistent with the color palette on the residence and must be mounted in a manner that does not conflict with or hide the architectural features of the residence, including but not limited to door or window trim and popouts, arches, mullions, etc.
- C. SOLAR SCREENS- Black, gray, or tan color may be installed without prior ARC approval. If installed on one window, all windows reasonably visible in the same vicinity must also have the same color solar screens installed.
- D. SOLAR PANELS- Before installing any solar panels on the roof of a residence, Owners must submit an Architectural Review Application Form. No solar or heating systems shall be constructed, erected, maintained, altered or changed on the lot until the plans and specifications showing the nature, kind, shape, materials, and location of the proposed Improvements have been submitted to and approved in writing by the ARC. The Architectural Review Application Form must be submitted and approved prior to the

commencement of such work. The decision of the ARC may be based on the harmony of the external design and location in relation to surrounding structures and topography.

1. Any pipes and external conduit must be painted to match the portion of the structure to which it is adjacent, to the extent possible.
2. SMRCA's preferred placement location for solar panels shall be on the main structure of the residence, located on the back side of the residence. If placing the solar panels on the back side of the residence decreases the efficiency or performance of the system by more than 10% of the amount originally specified for the system, then the Owner may propose other locations for the solar panels. Owner must provide proof of the same to ARC and obtain ARC approval prior to installation.
3. Each Owner shall maintain in good condition and repair, at his or her sole cost and expense, the solar panels located on the residence. Each Owner shall be solely responsible for any damage to Owner's residence, including the roof, which occurs during installation, maintenance and repair of the solar panels, or any damages caused by the solar panels. Any repairs, restoration or work to repair the roof, if such damage occurs, shall be performed in a good and workmanlike manner.
4. If at any time and in the sole discretion of the Board, the Association believes that the solar panels need to be maintained, repaired, replaced or restored, then the Association shall issue a letter to the Owner requiring the Owner to complete the necessary maintenance, repair, replacement or restoration within fifteen (15) days of the date of the letter.

E. PLAY EQUIPMENT- Play equipment that is placed in the rear yard that does not exceed the height of the side and rear yard walls, and is screened from view from the street, sidewalks, adjoining properties, and the Common Elements may be installed without ARC approval. Play equipment that does not meet these criteria requires ARC approval.

1. SPORT COURTS- An Owner may seek ARC approval for the installation and placement of a sport court, as long as it meets the following criteria:
 - a. The court must be set back at least five (5') feet from all property lines.
 - b. Landscape must be used to screen the court from view from the street, sidewalks, adjoining properties, and the Common Elements.
 - c. If exterior lighting is used, it must meet the requirements for exterior lighting set forth in these ARC Guidelines.
2. BASKETBALL BACKBOARDS AND HOOPS- Fixed backboards and hoops must be attached to a freestanding structure, must be located in the rear yard, and require ARC approval. Portable basketball hoops are considered pre-approved by the ARC, however they may NOT be kept in front yard or driveway and must be stored out of sight when not in use. Basketball hoops, portable or otherwise, may be visible through or above the side gate.

3. TRAMPOLINES – Trampolines with safety netting not exceeding ten (10) feet in height are permitted in the backyard only, without prior ARC approval. They should be placed in such a manner so as to minimize the impact on adjacent neighbors.

F. GARAGE CONVERSIONS- Are not permitted.

G. STORAGE SHEDS- Are allowed provided that they meet the following criteria:

1. The shed does not exceed six (6') in height at the eaves and eight (8') feet at the highest point of the roof.
2. It shall not exceed six (6') feet by eight (8') feet in area.
3. It is manufactured or painted in a color scheme to match the residence, including the roof.
4. If taller than the side or rear walls, it is not placed within five (5') feet of any side or rear property line.
5. It conforms to all applicable governmental codes and ordinances.

H. SATELLITE RECEIVERS AND OTHER PROTECTED ANTENNAS- the FCC has defined a Protected Antenna to include: (1) dish antennas one meter or less in diameter (39.37") designed to (a) receive direct broadcast satellite service or (b) receive/transmit fixed wireless signals via satellite; (2) antennas one meter or less in diagonal measurement designed to receive video via broadband radio service (wireless cable) or receive/transmit fixed wireless signals other than by satellite; and (3) an antenna of any size designed to receive local TV broadcast signal. In compliance with the Over-the-Air Reception Devices ("OTARD") rule, prior approval for the placement of Protected Antennas is not required. However, the placement of the Protected Antenna must conform to the Association's preferred placement specifications, to the extent possible.

1. Ground mounted satellite dishes or other Protected Antenna may not be larger than one (1) meter in diameter. Maximum allowable height from the ground to the top edge of the dish is five (5') feet.
2. Ground mounted satellite dishes or other Protected Antenna must be installed in the backyard and the satellite dish may not protrude above the surrounding perimeter fence.
3. Shrouded "umbrella style" ground mounted satellite dishes or other Protected Antenna are acceptable provided that location and height requirements are met and the dish is neutral in color.
4. Above ground mounted Protected Antennas must be installed on the side or back of the home, to the extent possible.
5. All components, including but not limited to brackets and plates, which attach the Protected Antenna to the structure must be fully located on either the side or back of the residence. The Protected Antenna must be attached at least one (1') foot away from the front of the residence.

6. The Protected Antenna must be installed on the residence, above the height of the perimeter wall.
7. When possible, efforts should be made to attach the Protected Antenna in such a manner so that it is camouflaged, at least partially, by plant life. (Please note that the addition of new plant life to your front or backyard requires prior approval.)
8. All wires associated with the Protected Antenna must be fully attached to the structure. They may not be loose and/or hanging.
9. Protected Antennas may not be attached to the perimeter wall and may not be freestanding on a tripod anywhere visible from the street.
10. Owners are fully responsible for the maintenance of all Protected Antennas and shall promptly repair, remove or replace any damaged, inoperable, or abandoned Protected Antenna.
11. In the event that none of the preferred placement specifications allow for the Owner to receive quality reception, after the installation of the Protected Antenna , the Owner shall provide written documentation from the installer to the Association attesting to that fact.

I. HOLIDAY LIGHTING and DECORATIONS- May be installed without ARC approval. Lighting and decorations must not be installed more than six (6) weeks prior to the recognized holiday and must be removed within two (2) weeks after the recognized holiday.

J. PAINTING- No permission or approval shall be required to repaint the residence consistent with an originally approved color scheme. No building, including without limitation, garages, shall be painted or repainted other than the original colors until the new color has been approved by the ARC.

The SMRCA has an Adopted Paint Palette, separate and apart from this document, which contains approved color schemes that may be used for the repainting of any residence within the community. An Architectural Review Application Form must be submitted prior to repainting.

1. Color schemes must be matched in their entirety. Colors may not be combined from different schemes and colors intended for body, garage and pop-outs, and fascia may not be used for any other component than what is designated by the palette.
2. The Adopted Paint Palette may be updated or amended from time to time, with notice to the membership.

K. TRASH CONTAINER STORAGE- Other than the day of trash pickup or the evening prior, all trash storage containers, including recycle bins, are to be stored out of sight of any street or neighboring residence. Any type of screening for trash containers may only be installed after approval of an Architectural Review Application.

X. Signage

A. ALARM SIGNAGE – is permitted without ARC approval provided the following:

1. One (1) sign supplied by, and indicating the name of a professional alarm system company is permitted to be visible from the street.
2. Sign must not exceed twelve (12”) inches by twelve (12”) inches in size.

B. WARNING/NOTICE SIGNAGE

1. Allowable sign types include “No Solicitation” and “Beware of Dog.”
2. One (1) sign per sign type per residence is allowed.
3. “No Solicitation” signs are allowed only in the window nearest to the front door and may not exceed four (4”) inches by six (6”) inches in size.
4. “Beware of Dog” signs are limited to eighteen (18”) inches by eighteen (18”) inches in size.

C. SPECIAL OCCASION SIGNAGE

1. Allowable sign types include birth announcements, and birthday, anniversary, and welcome home messages. Sports team signs, showing support for a given team immediately before, during or after major sporting events, are also included in this category.
2. One (1) sign per sign type per residence is allowed.
3. Signage may be displayed for a maximum of two (2) weeks.
4. All special occasion signs may not exceed two (2’) feet by three (3’) feet in size.

D. HOLIDAY SIGNAGE

1. May be displayed six (6) weeks prior to the recognized holiday and must be removed no more than two (2) weeks after the recognized holiday.

E. POLITICAL SIGNAGE

1. Political signs may not exceed twenty-four (24”) inches by thirty-six (36”) inches in size.
2. Owners may not exhibit more than one (1) political sign for each candidate, political party or ballot question.
3. Signs may be displayed for ninety (90) days before an election and no more than ten (10) days after.

4. As used in these guidelines, “Political signs” means a sign that expresses support for or opposition to a candidate, political party or ballot question in any federal, state or local election or any election of an association.

F. FOR SALE OR FOR RENT SIGNS

1. “For Sale” or “For Rent” signs must be commercially manufactured signs designed for this purpose and cannot be hand-written on miscellaneous materials.
2. One “For Sale” and “For Rent” sign, compliant with above-criteria, may be placed in the front yard of the residence without prior ARC approval.

G. GENERAL RULES APPLICABLE TO ALL SIGNAGE

1. No sign will be permitted to be placed on garage doors, on roofs or in any Common Elements.
2. All signs must be constructed of high quality materials and safely installed so as not to detach or deteriorate in inclement weather.
3. No signs may contain language, graphics, or any type of display that is patently offensive to the viewing public.
4. Signs not noted in these ARC Guidelines are prohibited, including but not limited to advertisements and marketing for products and services.
5. Owner is required to submit an Architectural Review Application form seeking approval for any sign that is intended to be permanent and decorative in nature, including but not limited to “Welcome” signs, name signs, house number signs (with the exception of the house number signs as installed by the developer) and wall or landscaping art.

XI. Security

Provided that the specifications below are met, Owners may proceed with installation of security devices without first submitting an Architectural Review Application. Any installation that does not meet the following ARC guidelines, requires submission of an application and prior approval.

A. SECURITY LIGHTING

1. Security lighting is defined as lighting installed on the exterior of the residence designed to preclude access to the property by unauthorized persons. Lighting designed to provide for the safety of authorized occupants of the property is included in this definition.

2. Security lighting must be intermittent; it cannot be installed to be on all of the time during darkness. Either manual or automatic controls may be used to control lighting, but security lighting may not remain on continuously.
3. Security lighting must be installed so as to minimize the impact on neighbors.
4. Security lighting may not exceed 300 watts per fixture.
5. Conduit for security lighting must be installed so that it is obscured from view to the extent possible, must be securely attached to the residence and must be painted to match the portion of the residence to which it is attached.

B. SECURITY CAMERAS

1. Security cameras are defined as standard surveillance equipment installed on the exterior of the residence designed to enhance the safety and security of the residence.
2. Security cameras must be installed in a manner so as to minimize the impact on neighbors. Security cameras shall not be installed in such a manner so that they directly surveil or intrude on the privacy of neighboring lots.
3. The number of security cameras affixed to the exterior of the residence shall not exceed four (4) visible from the street.
4. Conduit for security cameras must be installed so that it is obscured from view to the extent possible, must be securely attached to the structure and must be painted to match the portion of the residence to which it is attached.

XII. Vehicle Covers

A. COVERS FOR COMMERCIAL VEHICLES

1. No Commercial Vehicles (any vehicle with a sign displayed on any part thereof advertising any kind of business or other venture; or any vehicle on which racks, materials, ladders and/or tools are visible or any vehicle with a body type normally employed as a business vehicle whether or not a sign is displayed on any part thereof, or a truck greater than one (1) ton capacity, a van other than one used as a family passenger van, or a bus) may be parked on any driveway or part of the lot (aside from inside a closed garage) or within the Community unless adequately screened from view. A properly affixed, consistently applied, approved vehicle cover may be considered, dependent upon type of commercial vehicle, as an option to adequately screen the vehicle from view. Approved vehicle covers are those that are commercially manufactured for the purpose of covering a vehicle, neutral in color, made for and appropriate for the size of the

given vehicle, and maintained in good condition. Prior approval from the ARC is required.

2. No Recreational Vehicles (motorhomes, buses, trailer coaches, boats, other watercraft, aircraft or campers, etc.) may be parked on any driveway or other part of the lot (aside from inside a closed garage) or within the Community unless adequately screened from view. Approved Vehicle covers may be considered as an option to adequately screen the vehicle from view on a case-by-case basis and among other considerations, approvals will be dependent on the type of Recreational Vehicle. Prior approval from the ARC is required.
3. Inoperable vehicles are considered unsightly and are not permitted to be stored within the community. A vehicle cover shall not be used to obscure an inoperable vehicle from view. Inoperable vehicles include those that have flat tires, cob webs, and/or damage to windshields, bumpers or body of the vehicle that results in the vehicle not being reasonably operable or legally driven.

Appendix:

Architectural Submittal Checklist Exhibit A

SHADOW MOUNTAIN RANCH COMMUNITY ASSOCIATION *ARCHITECTURAL SUBMITTAL CHECKLIST*

EXHIBIT A

Please note: Incomplete submittals will cause a delay in the approval process.

Please read checklist carefully.

Below is a list of items that are required to accompany the application prior to review by the Architectural Review Committee.

1. Application (Exhibit B)
 - a. Complete Homeowner Information (name, address, telephone).
 - b. Homeowner's signature
 - c. Approximate start and completion dates
 - d. Project(s) being submitted.
2. Signed Neighbor Impact Statement (Exhibit C) – The Neighbor Statement is intended to make neighbors aware of any improvements that may impact their property. It is intended for advisory use only. "Impacted" refers to immediate surrounding areas affected by the improvement. "Facing" refers to most directly across the street. "Adjacent" refers to adjoining properties. "Rear" refers to neighbor(s) directly behind the property.
3. Plans Showing the Work to Be Done – Detailed drawings showing the height, length, width, color and what the improvement will look like when it is completed.
4. Landscape Plans – These plans show a diagram of your house and where the landscaping improvements will be. Indication of plant and tree types and locations is required.
5. Material Samples – Example: type of rock to be used, color chip of paint, pictures of gazebo, pool, patio cover and spa should accompany the plan for the same. A detailed drawing or picture must be submitted.

Send Application and plans to:

**Shadow Mountain Ranch Community Association
Architectural Review Committee
c/o Level Community Management
8966 Spanish Ridge Ave. Suite 100
Las Vegas, NV 89148**

Failure to follow these requirements and procedures may cause your request to be delayed pending submission of additional information and documentation to the Architectural Review Committee. An incomplete application may affect the time limits for approval.

Architectural Review Application Form Exhibit B

ARCHITECTURAL REVIEW APPLICATION FORM: THIS FORM MUST BE COMPLETED AND PROJECT APPROVED PRIOR TO COMMENCEMENT OF IMPROVEMENTS, CHANGES, ETC. Submit to SMRCA c/o Level Community Management, 8966 Spanish Ridge Ave Ste 100, Las Vegas, NV 89148 phone: (702)433-0149 fax: (702)444-2416 email: Help@levelprop.com

DATE: _____ ESTIMATED COMPLETION DATE: _____

NAME: _____ H. PHONE: _____ C. PHONE: _____

ADDRESS: _____ E-MAIL: _____

Application is submitted for review and approval of the following described improvements. Anything not listed here and not clearly shown on plans and specifications will not be a part of this review. You must provide a phone number.

DESCRIPTION OF PROPOSED IMPROVEMENTS:

In support of this application, the following required items **must** be submitted:

- One copy of plans and specifications
- Show proposed improvements, including names of plants, proposed materials, surfaces finishes, colors and dimensions
- A completed Neighbor Awareness Form (**APPLICATIONS WITHOUT A COMPLETED NEIGHBOR AWARENESS FORM MAY BE AUTOMATICALLY REJECTED**)

If application is incomplete, the reviewer will notify the applicant as to the needed documents or information and the application will not be further considered until receipt of these materials or information.

I will assume the responsibility of any work under the proposed above improvement that I may or my licensed contractor may accomplish which may, in the future, adversely affect the common area. I will assume responsibility for all future maintenance of this addition and/or improvement.

Homeowner's Signature _____ Date _____

FOR ARCHITECTURAL COMMITTEE USE ONLY

Action taken by Architectural Review Committee:

- APPROVED AS SUBMITTED
- APPROVED WITH CONDITIONS (The request submitted is approved subject to the conditions noted.)
- DISAPPROVED (The entire request is not approved and must be resubmitted.)
- NEED MORE INFORMATION (The request does not have enough information. Please collect the requested information and re-submit to ARC).

Comments:

Signature of ARC Member: _____ Date: _____

This approval does not relieve the Owner from CC&R requirements nor does it constitute approval as to compliance with applicable State or County Ordinances or requirements. Owner may also need to acquire building permits and/or approval from the County for permission to encroach or County easements. Approval is not to be considered authorization to change the drainage as installed by the developer and approved by the County.

Impacted Neighbor Statement Exhibit C

ARCHITECTURAL REVIEW APPLICATION NEIGHBOR AWARENESS FORM

THIS FORM MUST BE COMPLETED AND APPROVED PRIOR TO COMMENCEMENT OF ANY IMPROVEMENTS, CHANGES, ETC.

OWNER'S NAME: _____

ADDRESS: _____

FACING NEIGHBOR: _____

ADDRESS: _____ Phone _____

I have reviewed the plans and specifications for my neighbor's proposed improvements. My comments are noted below. (Check one)

- I have no concerns about the proposed improvements in regards to impact on my property.*
- I have the following concerns regarding the impact on my property.*

Signature

Date

REAR NEIGHBOR: _____

ADDRESS: _____ Phone _____

I have reviewed the plans and specifications for my neighbor's proposed improvements. My comments are noted below. (Check one)

- I have no concerns about the proposed improvements in regards to impact on my property.*
- I have the following concerns regarding the impact on my property.*

Signature

Date

ADJACENT NEIGHBOR: _____

ADDRESS: _____ Phone _____

I have reviewed the plans and specifications for my neighbor's proposed improvements. My comments are noted below. (Check one)

- I have no concerns about the proposed improvements in regards to impact on my property.*
- I have the following concerns regarding the impact on my property.*

Signature

Date

ADJACENT NEIGHBOR: _____

ADDRESS: _____ Phone _____

I have reviewed the plans and specifications for my neighbor's proposed improvements. My comments are noted below. (Check one)

- I have no concerns about the proposed improvements in regards to impact on my property.*
- I have the following concerns regarding the impact on my property.*

Signature

Date

Completion of the Neighbor Awareness Form does not constitute approval by the ARC.

Patio Cover Checklist Exhibit D**SHADOW MOUNTAIN RANCH
COMMUNITY ASSOCIATION*****PATIO COVER CHECKLIST*****EXHIBIT D**

The following information is needed for all patio cover submittals. This information must be accompanied by plans **that show all of the listed details**, dimensions and what the completed cover will look like.

1. Height _____ Slope _____
Width _____ Overhang _____
2. Setbacks must be clearly indicated on the site plan, meet all code requirements and be approved by the Architectural Review Committee.
3. Roof type: _____ (A or B)
 - A. Flat with spaced slats? Yes or No
If yes, will roof have exposed rafters? Yes or No

What is the spacing of the slats? _____
 - B. Matches existing roof type.
4. Material type: _____
5. Post Diameter: _____
6. Color:
 - A. Will structure be painted to match the color of the residence? Yes or No
 - B. Is the natural color of the wood being used? Yes or No
(All natural wood surfaces must be finished.)
7. Stucco – will patio cover be stuccoed? Yes or No
(If yes, stucco must match the stucco type and color that is on the residence.)

NOTE: Owners remain permanently responsible for the maintenance and upkeep of additions and modifications to their property and must be recorded with their deed.

Driveway Extensions Illustrations Exhibit E

Please refer to the following three illustrations:

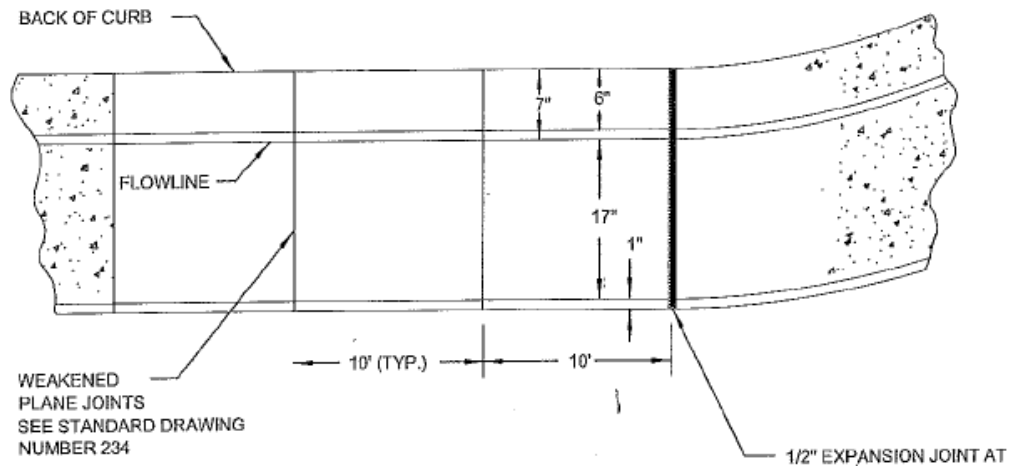

PLAN

NOTES:

- 1" BATTER ON GUTTER FACE OPTIONAL.
- WHERE LONGITUDINAL SLOPE IS LESS THAN 0.4%, THE FLOW LINE SHALL BE WATER TESTED.

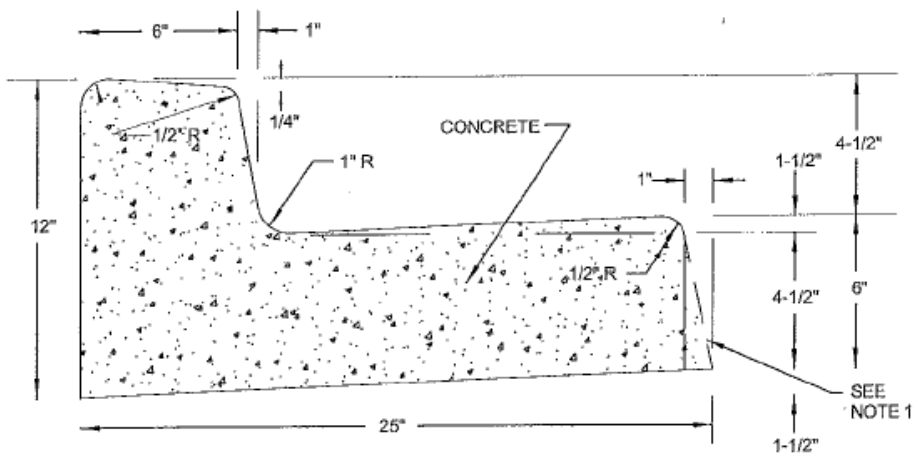

TYPICAL SECTION

SPECIFICATION REFERENCE		UNIFORM STANDARD DRAWINGS CLARK COUNTY AREA
501	CONCRETE	"L" TYPE CURB AND GUTTER
502	CONCRETE STRUCTURES	
707	JOINT MATERIAL	

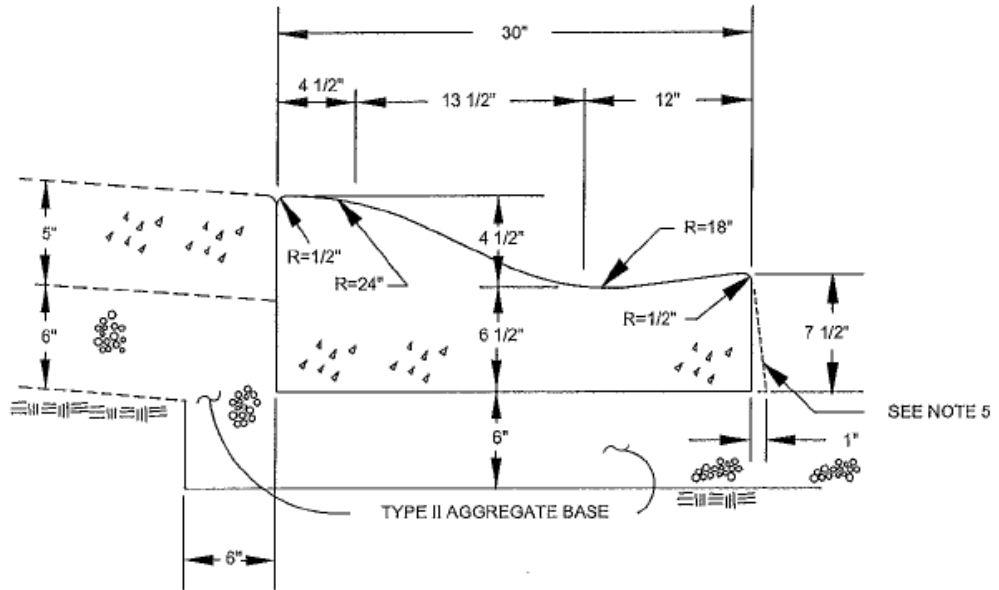

NOTES:

1. USE OF ROLL CURB MAY BE RESTRICTED BY SURFACE DRAINAGE CONSIDERATIONS.
2. SIDEWALK CONSTRUCTED CONTIGUOUS TO ROLL CURB SHALL BE 5 INCHES THICK (MIN).
3. WHERE LONGITUDINAL SLOPE IS LESS THAN 0.4% THE FLOW LINE SHALL BE WATER TESTED.
4. CONSTRUCT 1/2" EXPANSION JOINT AT ALL COLD JOINTS, AT BEGINNING AND END OF CURB RETURNS, AND AT 300 FT. MAX. INTERVALS FOR EXTRUDED CURB AND 30 FT. MAX. INTERVALS FOR FORMED CURB. WEAKENED PLANE JOINTS SHALL BE FORMED AT THE REMAINING 15 FT. INTERVALS. SEE STD. DWG. NO. 234 FOR JOINT DETAILS.
5. ONE INCH BATTER AT CURB FACE IS OPTIONAL.
6. CITY OF LAS VEGAS COUNCIL APPROVAL REQUIRED FOR USE OF 30" ROLL CURB IN THE CITY OF LAS VEGAS.
7. IN NORTH LAS VEGAS, ROLL CURBS ARE PROHIBITED IN AREAS WHERE FLOW LINE GRADIENT IS LESS THAN 0.8% UNLESS OTHERWISE APPROVED BY CITY ENGINEER.
8. ALL UTILITY BOXES AND COVERS ADJACENT TO ROLL CURB SHALL BE HS-20 RATED "TRAFFIC BEARING" TYPE

SPECIFICATION REFERENCE		UNIFORM STANDARD DRAWINGS CLARK COUNTY AREA CLARK COUNTY, LAS VEGAS, NORTH LAS VEGAS, AND HENDERSON ONLY 30" ROLL CURB RESIDENTIAL AREA
320	AGGREGATE BASE	
501	CONCRETE	
502	CONCRETE STRUCTURES	
707	JOINT MATERIAL	
		DATE 11-10-04 DWG. NO. 217A PAGE NO. 23A

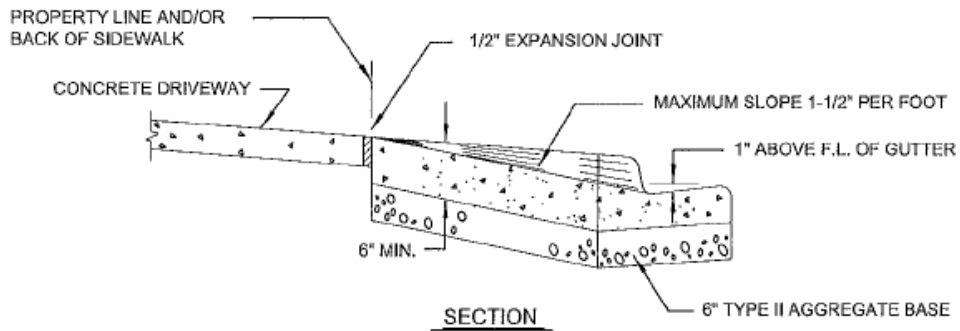
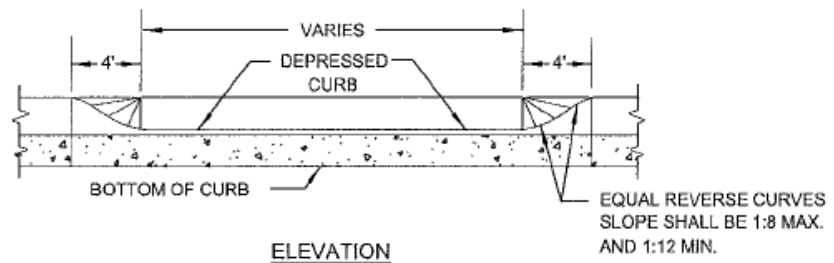
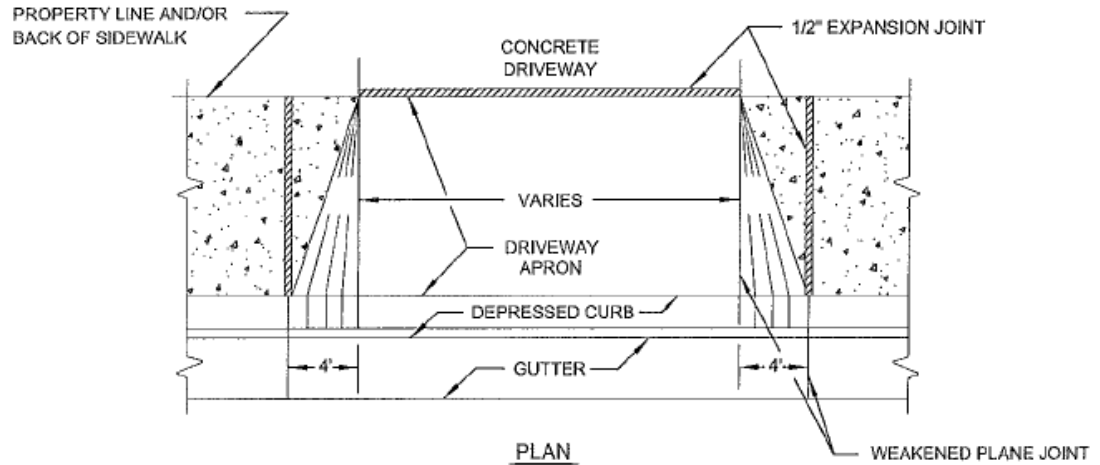

NOTES:

1. WHEN CONSTRUCTING DRIVEWAY WHERE CURB AND GUTTER EXISTS, COMPLETELY REMOVE INTERFERING PORTIONS OF EXISTING CURB AND GUTTER. DRIVEWAYS MAY BE MONOLITHIC TO A.C. LINE.
2. WEAKENED PLANE JOINTS SHALL BE UNIFORMLY PLACED BETWEEN 6' AND 7' INTERVALS, SEE STANDARD DRAWING NO. 234.

SPECIFICATION REFERENCE		UNIFORM STANDARD DRAWINGS CLARK COUNTY AREA	
302	AGGREGATE BASE	RESIDENTIAL DRIVEWAY	
501	CONCRETE		
502	CONCRETE STRUCTURES		
707	JOINT MATERIAL		
		DATE 12-14-00	DWG. NO. 223
		PAGE NO. 29	